

Technical decision RRJ0000-OR-470-4950

on continued airworthiness of aeroplane RRJ-95 with deactivated EPAS system of entrance/service doors in automatic mode

During the current aeroplane operation with implemented AD №2020-FATA-01020A-04, the cases of incorrect slide operation during scheduled maintenance while opening the doors manually with the damper non operative were detected. Based upon the results of investigation, it's defined a need to amend the manual door opening procedure in case of slide emergency extension with the installation of additional placards instructing the correct opening procedure.

The following decision is taken for Continued Airworthiness of Aircraft RRJ-95:

DECISION:

1. During nearest WY Check (8 days) on aeroplane RRJ-95 with door arms p/n A415406-001 Rev.E, A415406-003 Rev.E, A415406-005 Rev.E and A415406-006 Rev.E to install new and shift earlier installed placards: on front passenger doors (see Fig.1, Fig.4, Fig.5), front service door (see Fig.2, Fig.4, Fig.5) rear passenger and service door (see Fig 3, Fig.4, Fig 5) in accordance with AMM task 11-00-00-900-801 «Installation and removal of inscriptions»
2. **Note:** In case the aeroplane has at least one door arm p/n A415406-001 Rev.E, A415406-003 Rev.E, A415406-005 Rev.E and A415406-006 Rev.E the requirements of Technical Decision RRJ0000-OR-470-4159/A must be fully completed.
3. Upon the fulfilling of paragraph 1, to perform the opening of entrance and service doors manually with emergency slide extension in accordance with AMM task 52-10-00-010-802 «Opening of entrance and service doors in manual or automatic modes with emergency slide extension » and Chapters 03.60 and 10.30 of Cabin Crew Operational Manual (CCOM) accordingly.
4. To continue aeroplane standard operation with door arms p/n A415406-001 Rev.E, A415406-003 Rev.E, A415406-005 Rev.E and A415406-006 Rev.E in accordance with this Technical decision till the SB implementation RRJ-52-00485-БД « Doors, hatches, access doors - Passenger and crew doors – Replacement of EPAS» but no later than 30.11.2023

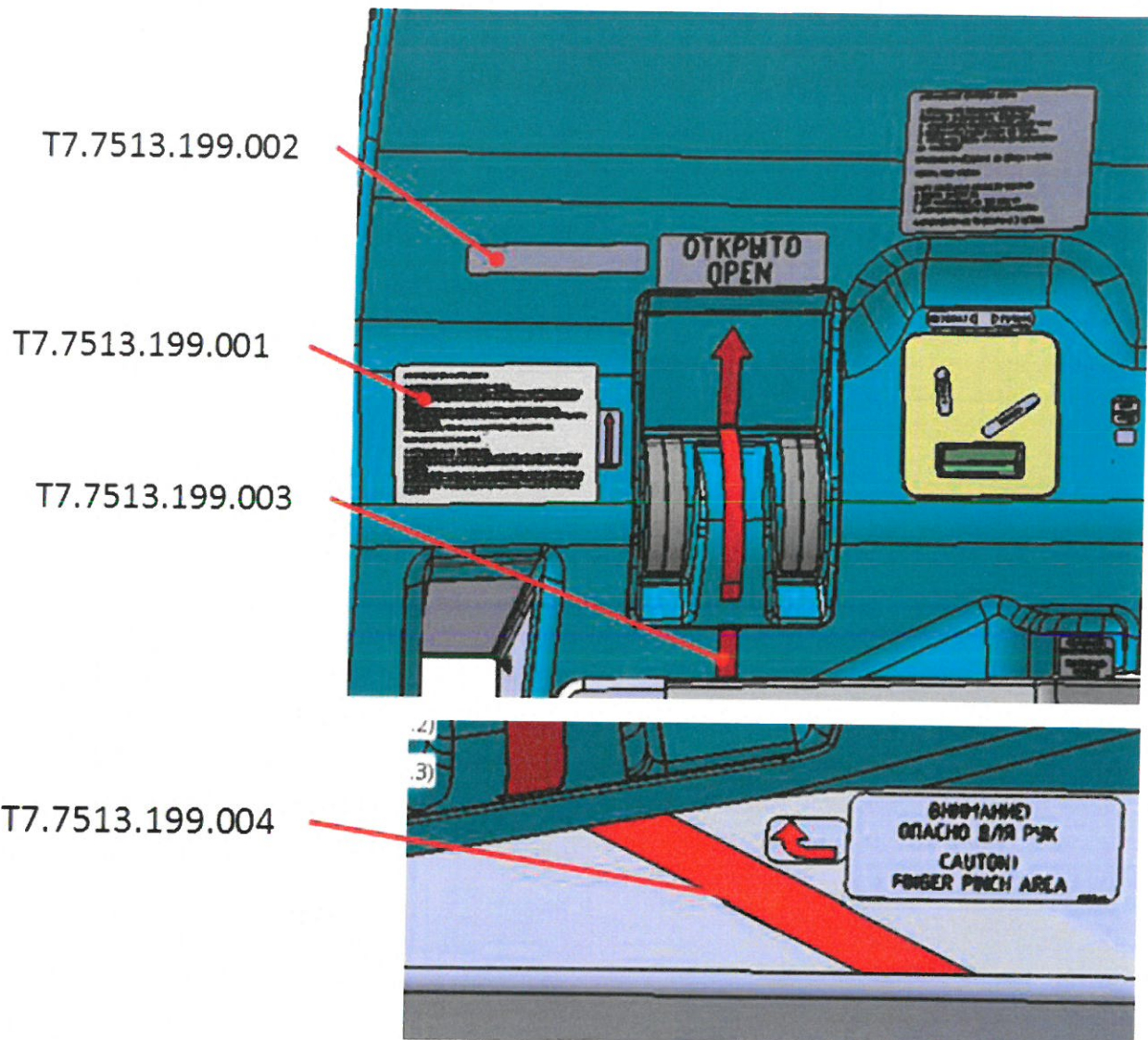

Door support arm cover

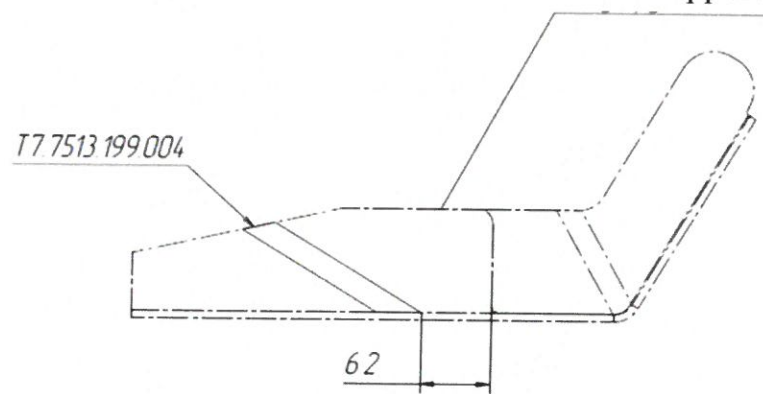
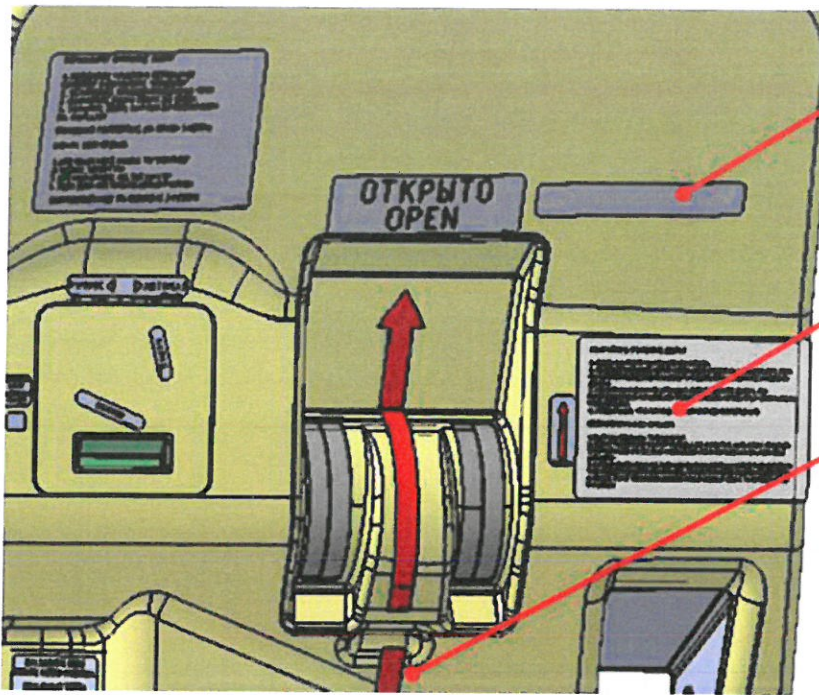

Fig. 1 (Front passenger door)



T7.7513.199.002

T7.7513.199.001

T7.7513.199.003

T7.92.7513.005

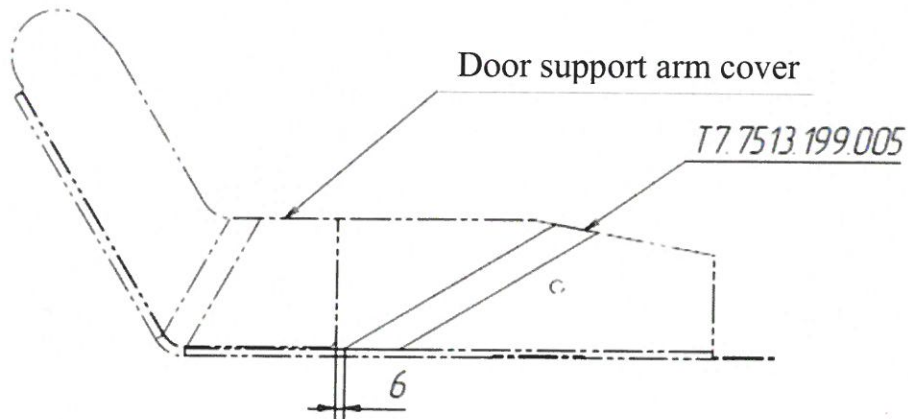
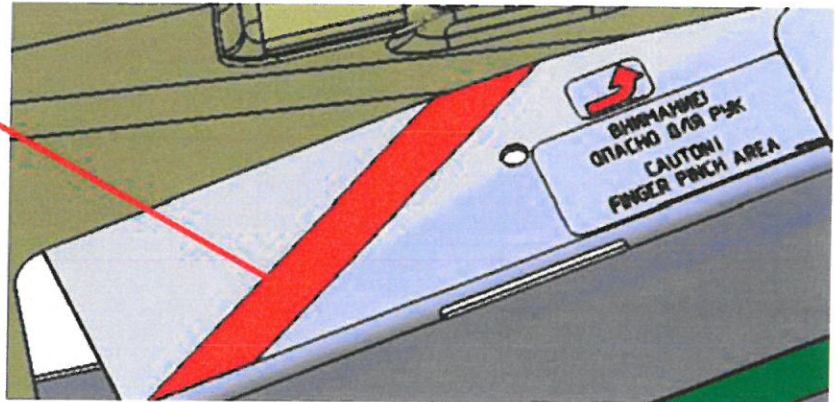
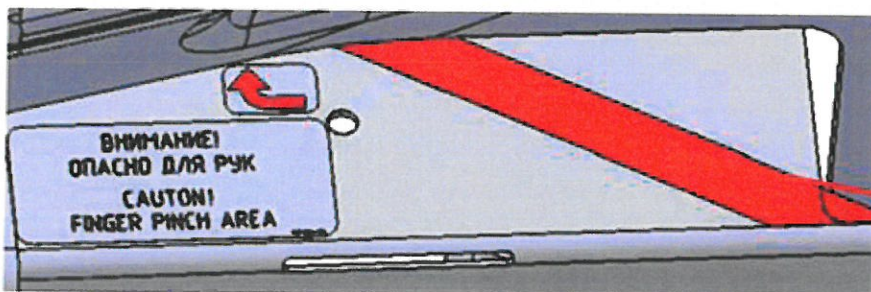
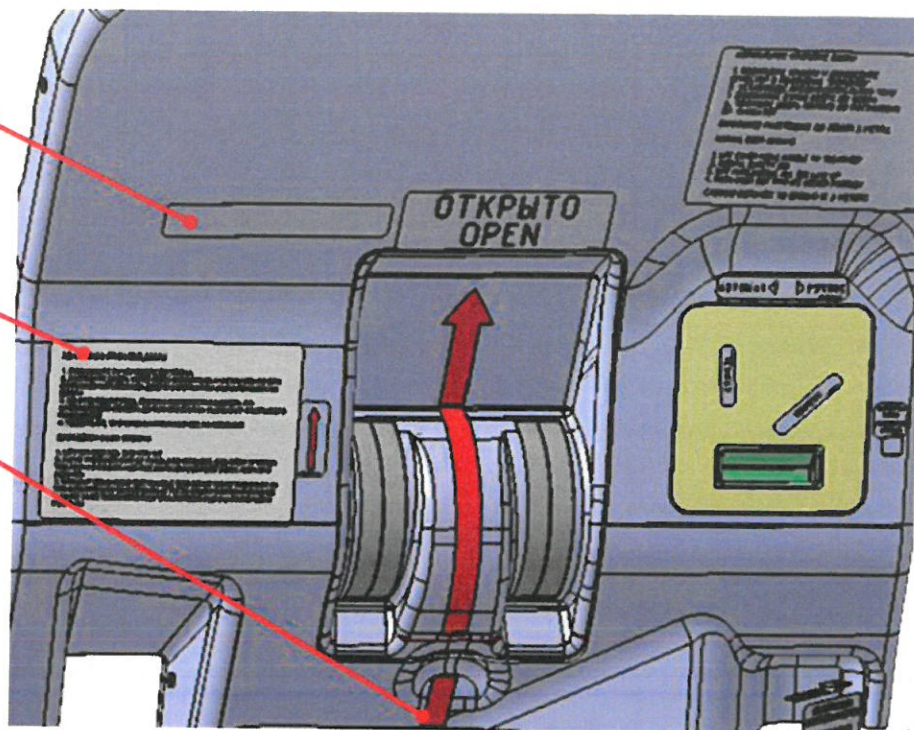

Fig. 2 (Front service door)

T7.7513.199.002

T7.7513.199.001

T7.7513.199.003



T7.92.7513.006
for rear passenger
door

T7.92.7513.007
for rear service
door

Door support arm cover

T7.7513.199.006 - rear passenger door
T7.7513.199.007 - rear service door (mirrored)

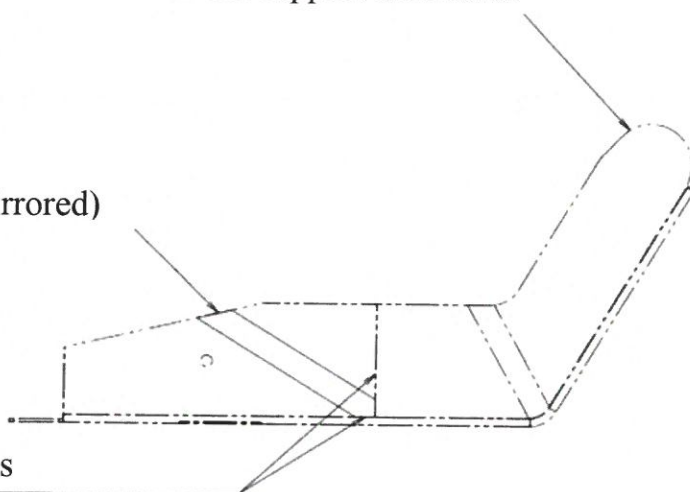

The installation of the placards

Fig. 3 (Rear passenger and service door)

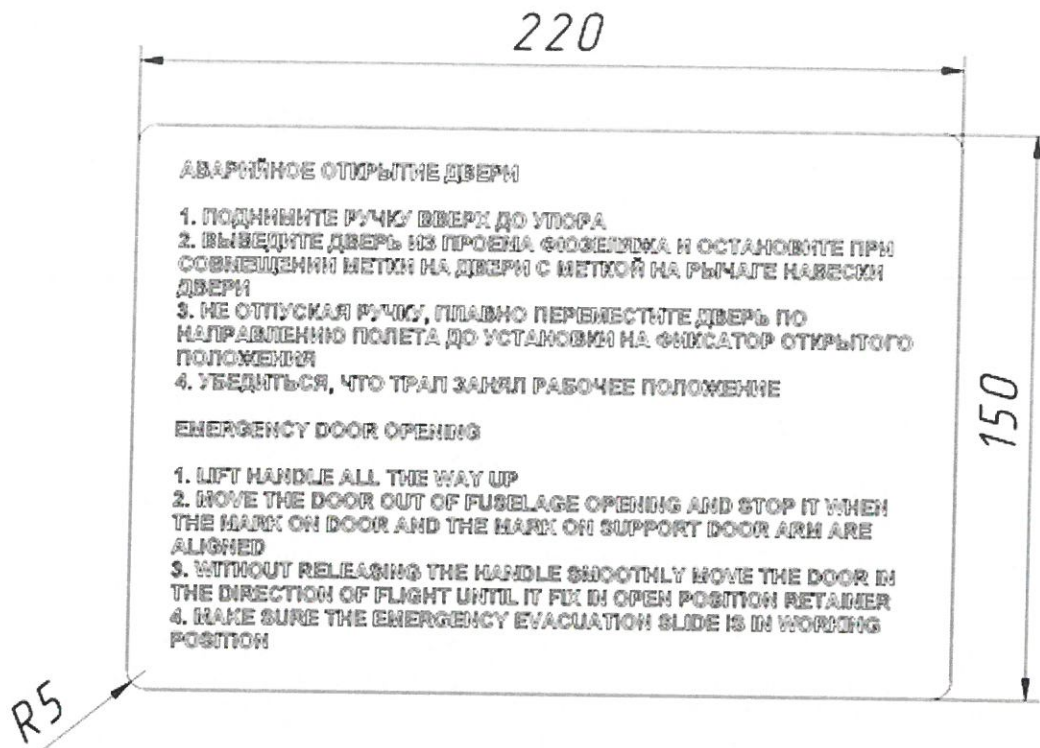

T7.7513.199.001

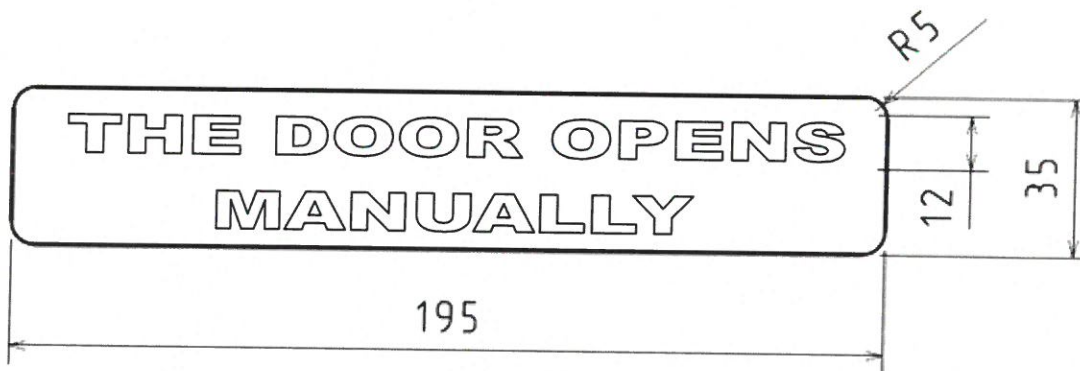

T7.7513.199.002

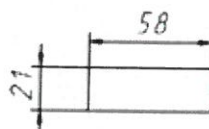

T7.7513.199.003

Fig. 4 Placards

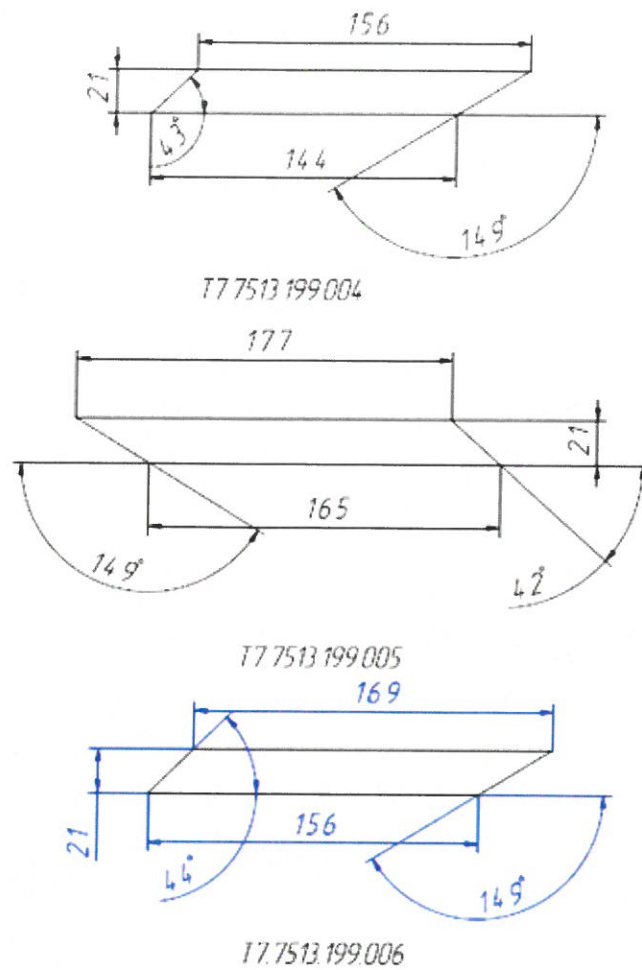

Fig. 5 Placards

Appendix: AMM task № 52-10-00-010-802 «Opening of entrance and service doors in automatic or manual modes with emergency slide extension» on 8 pages, 1 copy.